

RECOMMANDATIONS LOGEMENTS

d: h9
D: H10
E: +0,2

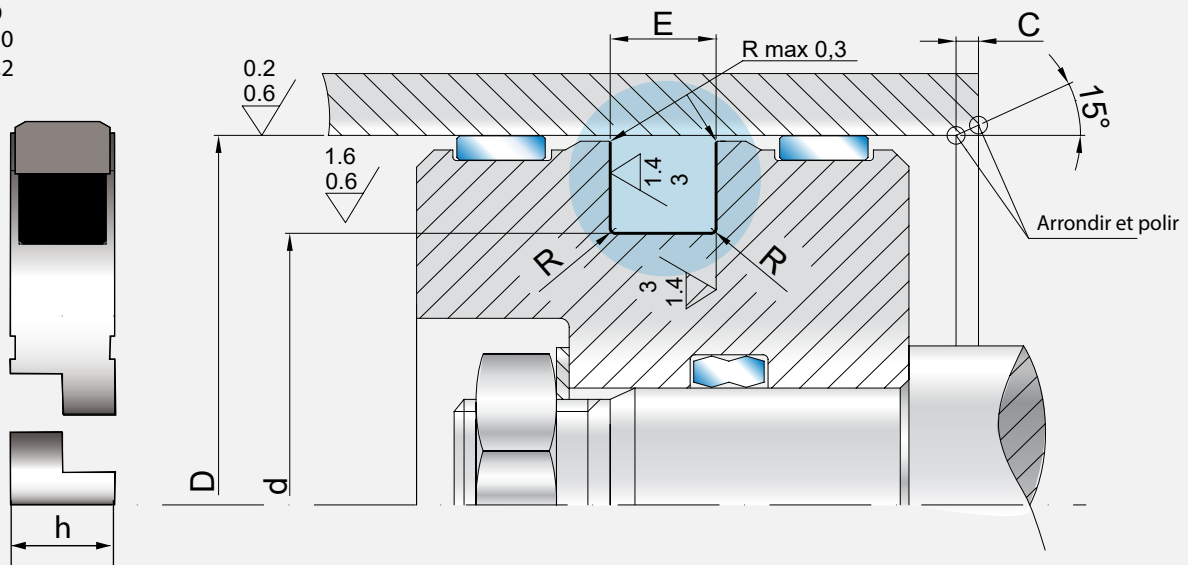

	TX	PSQ	PSO	SPW	PSZ	PHP	KSP
Température c°	-30 +100	-35 +100	-35 +100	-30+100	-30 +100	-35 +100	-30 +100
Pression Bar	<800	<400	<400	<500	<800	<400	<400
Vitesse m/s	<15	<0,8	<0,5	<1,5	<1	<0,8	<10
Matière	PB-NBR	PU(98)-NBR	PU(98)-NBR	PB-POM-NBR	PA66-NBR	PU-NBR-POM	PB-NBR
Hydrau/Pneum	H	H	H	H	H	H	H

TX et KSP : + 200°C avec OR et bague FPM

VEUILLEZ NOTER, QUE NOUS POUVONS PRODUIRE CES PROFILS SELON VOS BESOINS, DANS DIFFERENTES MATIÈRES ET DANS DES LOGEMENTS NON-STANDARDS. (SAUF PSZ)

