

JPSE: JOINT DE PISTON SIMPLE EFFET

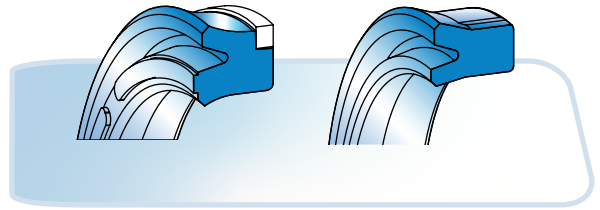

Le joint de piston simple effet est un joint "U" lèvres asymétrique avec ou sans bague anti-extrusion.

RECOMMANDATIONS LOGEMENTS

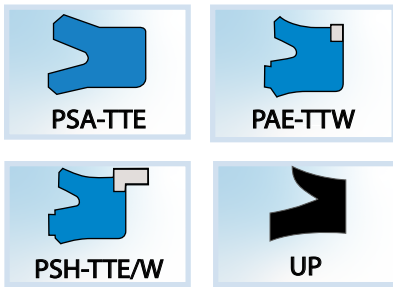
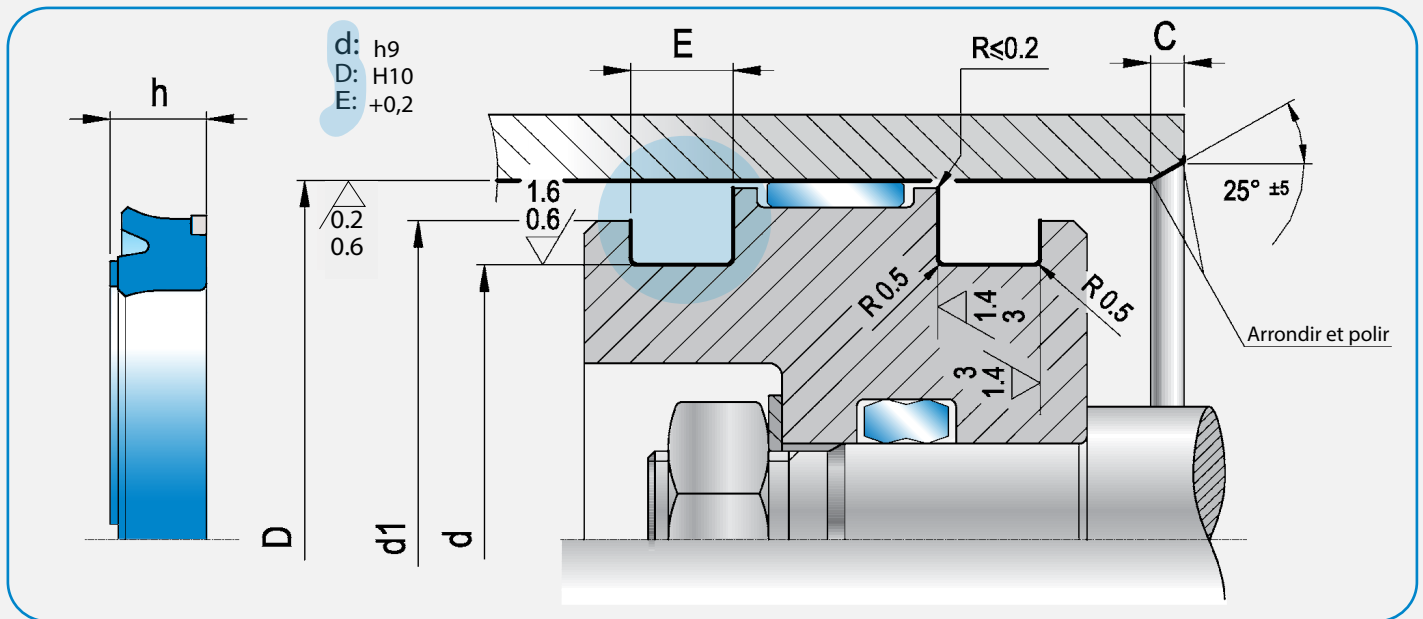

	PSA TTE	PAE TTW	PSH TTE/W	UP
Température c°	-35 +100	-35 +100	-35 +100	-30 +100
Pression Bar	<400	<500	<400	<80
Vitesse m/s	<0,5	<0,5	<0,5	<0,3
Matière	PU	PU-POM	PU-POM	NBR 90sh
Hydrau/Pneum	H	H	H	H
Indice matière	3	1	3	6

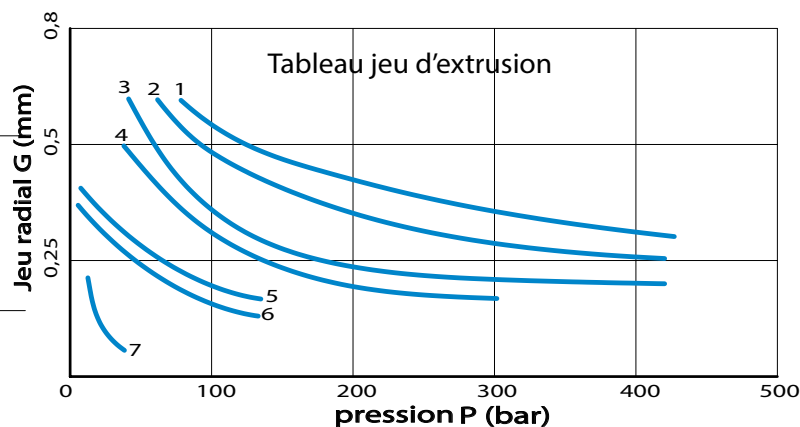

- 1 - polyurethane 93 Shore A avec bague anti extrusion
- 2 - polyurethane 98 Shore A
- 3 - polyurethane 93 Shore A
- 4 - polyurethane 90 Shore A
- 5 - polyurethane 85 Shore A
- 6 - NBR 90 Shore A
- 7 - NBR 70 Shore A